



# WS30P4N3H

## Transient Voltage Suppressor

### Features

- 7400 Watts Peak Power ( $t_p = 8/20\mu s$ )
- Excellent Clamping Capability
- Low profile package
- Solid-state silicon technology
- Working Voltages: 30V

### IEC COMPATIBILITY (EN61000-4)

- IEC 61000-4-2 (ESD)  $\pm 30kV$  (air),  $\pm 30kV$  (contact)
- IEC 61000-4-4 (EFT) 40A (5/50ns)
- IEC 61000-4-5 (Lightning) 200A (8/20 $\mu s$ )

### Mechanical Characteristics

- DFN2020-3L package
- Marking : Marking Code
- Packaging : Tape and Reel per EIA 481
- RoHS Compliant & HF

### Applications

- I/O Interfaces
- Power lines
- Automotive and Telecommunication
- Computer & Consumer Electronics
- Industrial Electronics
- Microcontroller Input Protection

### PIN Configuration

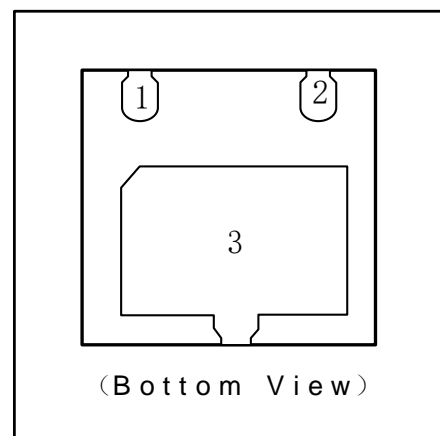
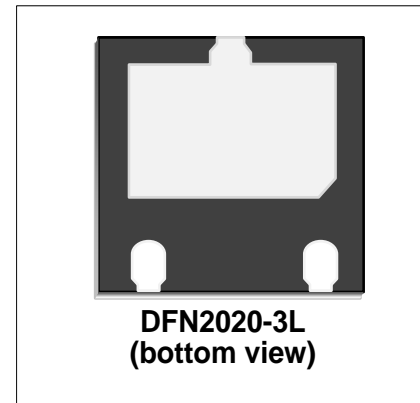
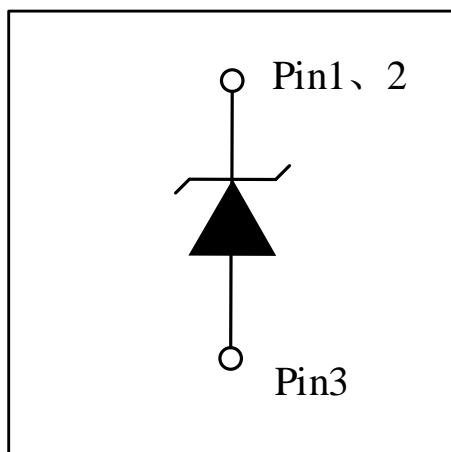

Absolute Maximum Rating			
Rating	Symbol	Value	Units
Peak Pulse Power ( $t_p = 8/20\mu s$ )	P <sub>PP</sub>	7400	Watts
Peak Pulse Current ( $t_p = 8/20\mu s$ )	I <sub>PP</sub>	200	A
Operating Temperature	T <sub>J</sub>	-55 to + 125	°C
Storage Temperature	T <sub>STG</sub>	-55 to +150	°C

**Electrical Parameters**

Symbol	Parameter
I <sub>PP</sub>	Reverse Peak Pulse Current
V <sub>C</sub>	Clamping Voltage @ I <sub>PP</sub>
V <sub>RWM</sub>	Reverse Stand-Off Voltage
I <sub>R</sub>	Reverse Leakage Current @ V <sub>RWM</sub>
V <sub>BR</sub>	Breakdown Voltage @ I <sub>T</sub>
I <sub>T</sub>	Test Current
I <sub>F</sub>	Forward Current
V <sub>F</sub>	Forward Voltage @ I <sub>F</sub>

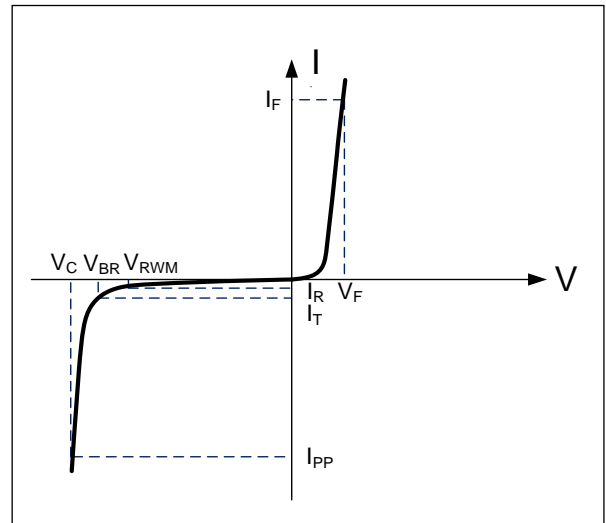

**Electrical Characteristics(T=25°C unless otherwise noted)**

WS30P4N3H						
Parameter	Symbol	Conditions	Minimum	Typical	Maximum	Units
Reverse Stand-Off Voltage	V <sub>RWM</sub>				30	V
Reverse Breakdown Voltage	V <sub>BR</sub>	I <sub>T</sub> =1mA	30.5		35	V
Forward Voltage	V <sub>F</sub>	I <sub>F</sub> =10mA	0.5		1.5	V
Reverse Leakage Current	I <sub>R</sub>	V <sub>RWM</sub> =30V, T=25°C			500	nA
Clamping Voltage <sup>1</sup>	V <sub>C</sub>	I <sub>PP</sub> =200A, t <sub>p</sub> =8/20μs		34.5	37	V
Dynamic Resistance <sup>2,3</sup>	R <sub>DYN</sub>	TLP=0.2/100ns		0.06		Ω
ESD Clamping Voltage <sup>1</sup>	V <sub>C</sub>	I <sub>PP</sub> = 4A, t <sub>p</sub> = 0.2/100ns (TLP)		31.9		V
ESD Clamping Voltage <sup>1</sup>	V <sub>C</sub>	I <sub>PP</sub> = 16A, t <sub>p</sub> = 0.2/100ns (TLP)		32.6		V
Junction Capacitance	C <sub>j</sub>	V <sub>R</sub> = 0V, f = 1MHz		600	720	pF

Note: 1.Measured from pin 1& pin 2 to pin 3;  
 2.TLP Setting : t<sub>p</sub>=100ns, t<sub>r</sub>=0.2ns, I<sub>TLP</sub> and V<sub>TLP</sub> sample window:t<sub>1</sub>=70ns to t<sub>2</sub>=90ns;  
 3.Dynamic resistance calculated from I<sub>PP</sub>=4A to I<sub>PP</sub>=16A using "Best Fit".

Typical Characteristics

Figure 1: Peak Pulse Power vs. Pulse Time

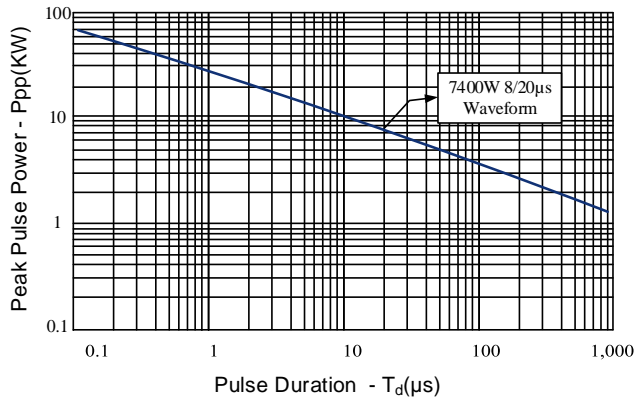

Figure 2: Power Derating Curve

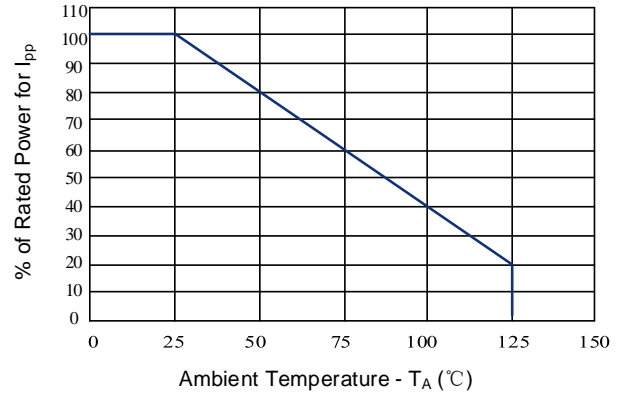

Figure 3: Clamping Voltage vs. Peak Pulse Current

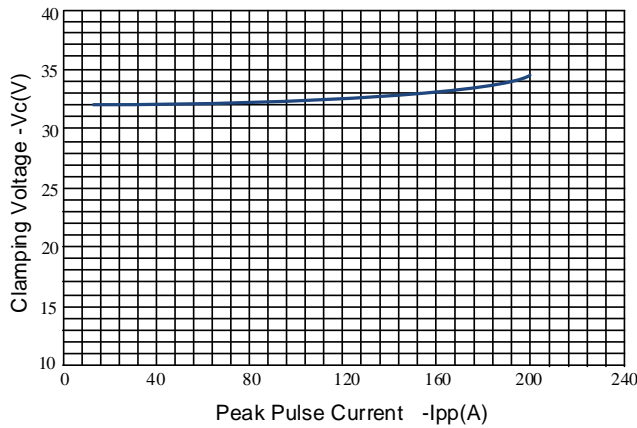

Figure 4: Normalized Junction Capacitance vs. Reverse Voltage

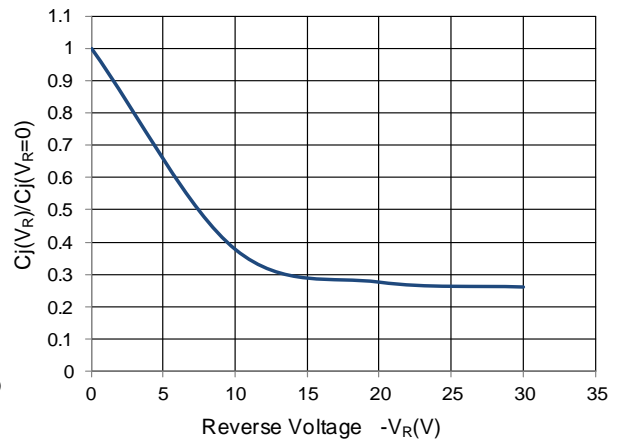

Figure 5: 8/20µs Pulse Waveform

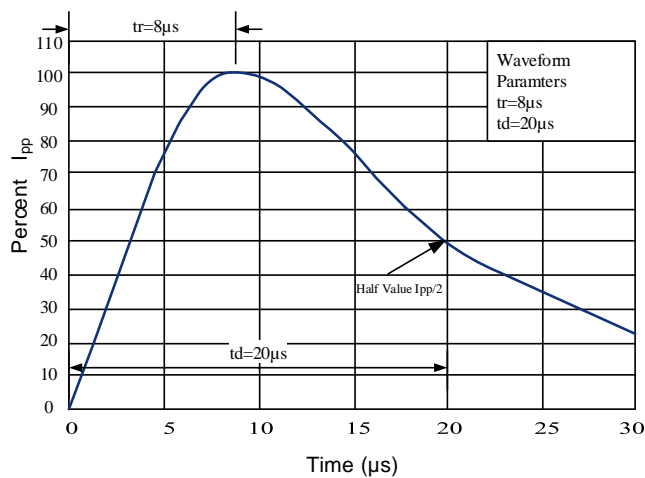
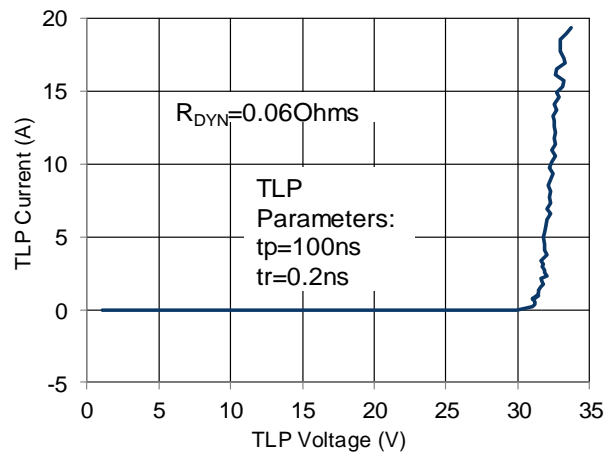
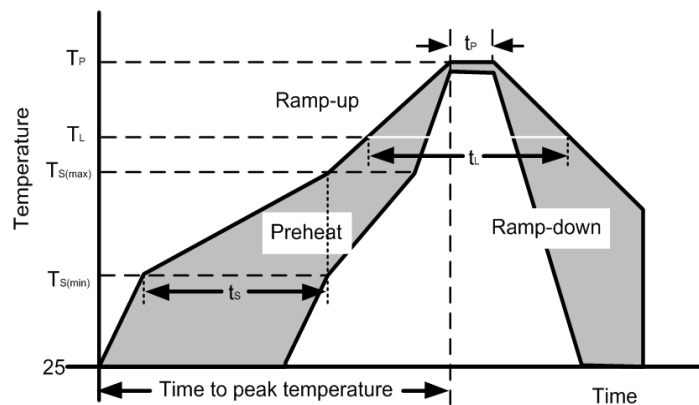

Figure 6: TLP I-V Curve



Soldering Parameters

Reflow Condition		Pb – Free assembly
Pre Heat	Temperature Min ( $T_{s(min)}$ )	150°C
	Temperature Max ( $T_{s(max)}$ )	200°C
	Time (min to max) ( $t_s$ )	60 – 190 secs
Average ramp up rate (Liquidus Temp) ( $T_L$ ) to peak		5°C/second max
$T_{s(max)}$ to $T_L$ —Ramp-up Rate		5°C/second max
Reflow	Temperature ( $T_L$ ) (Liquidus)	217°C
	Temperature ( $t_L$ )	60 – 150 seconds
Peak Temperature ( $T_P$ )		260+0/-5 °C
Time within actual peak Temperature ( $t_p$ )		20 – 40 seconds
Ramp-down Rate		5°C/second max
Time 25°C to peak Temperature ( $T_P$ )		8 minutes Max.
Do not exceed		280°C



Outline Drawing –DFN2020-3L

### PACKAGE OUTLINE

TOP VIEW

BOTTOM VIEW

SIDE VIEW

**DFN2020-3L**

SYMBOL	MILLIMETERS		
	MIN	NOM	MAX
A	0.50	0.55	0.60
A1	0.00	0.02	0.05
b	0.25	0.30	0.35
b1	0.20REF		
c	0.152REF		
D	1.90	2.00	2.10
D2	1.40	1.50	1.60
e	1.30BSC		
E	1.90	2.00	2.10
E2	0.95	1.05	1.15
E3	0.20	0.30	0.40
L	0.35	0.40	0.45
L1	0.20	0.25	0.30
h	0.20REF		
K	0.20	0.30	0.40

### Land Pattern

### Marking Codes

Part Number	Marking Code	
WS30P4N3H		M30H=Specific Device Code XXXX=Lot Code

### Package Information

Qty: 3k/Reel

### CONTACT INFORMATION

No.1001, Shiwan (7) Road, Pudong District, Shanghai, P.R.China.201207

Tel: 86-21-68969993 Fax: 86-21-50757680 Email: [market@way-on.com](mailto:market@way-on.com)

WAYON website: <http://www.way-on.com>

For additional information, please contact your local Sales Representative.

**WAYON** ® is registered trademark of Wayon Corporation.

Specifications are subject to change without notice.  
 The device characteristics and parameters in this data sheet can and do vary in different applications and actual device performance may vary over time.  
 Users should verify actual device performance in their specific applications.